



PS Laptop Management Cart with pre-installed Cat 6 Ethernet cables

ERGOTRON®

PowerShuttle® (PS) Laptop Management Cart
PowerShuttle (PS) Laptop Charging Cart

Highlights

Universal Design

- Open-architecture design works with laptops, netbooks and tablets with displays up to 15.6". Maximum device size 15.1"W x 11"D x 1.69"H (38,4 x 28 x 4,3 cm)
- Country-specific power strip is provided to plug in 20 AC adapters. Unique, flexible design accommodates a variety of brick and plug styles for laptops, netbooks and tablets that won't fit in standard outlet strips

PowerShuttle® Technology

- Efficiently scans the system and distributes power to optimize total charge time for the laptops and prevent overloading electrical circuits at the same time

Durable, Secure Storage

- Robust key and lock assembly keeps devices secure. Double-hinged, locking steel front doors with recessed handle open 180° to reveal notebook storage shelves
- Rugged steel frame construction, steel front and rear doors, and molded fire-rated ABS exterior withstands heavy use of classroom settings
- For user and equipment safety, the entire cart is tested and certified to UL 60950 and 1667 standards
- Secure back compartment provides IT access to power brick storage and power strips. Clean, neat cable management runs power to units

Easy to Use

- Lightweight, up to 49% smaller than competitive product, this compact cart design makes it easy to safely move from room to room
- Ships fully assembled
- Four 4" (10 cm) medical-grade, dual-wheel locking casters allow easy push/pull mobility



*Charges. Manages.
 Compact, secure and cost-effective design.*

Buying the right laptops is only one piece of the puzzle. Securely storing, deploying and managing those important assets while making it easy for staff is equally important. This cart's universal interface charges and manages software on up to 20 devices (works with laptops, netbooks and tablets). Patented PowerShuttle Load Sensing Technology optimizes total charge time while safely preventing electrical circuit overload by efficiently grouping the number of devices that are charged at one time. Works in any environment, including education, healthcare and enterprise applications.

**JUST
 STAND
 .ORG**



PS Laptop Management Cart (switch not included)



CERTIFICATION

UL 60950 Safety of Information Technology Equipment, CAN/CSA C22 2 No. 60950

UL 1667 Tall Institutional Carts for use with Audio, Video and Television Type Equipment

ICES-003 Issue 4, Class A

FCC Part 15 Class A

Country-specific certification as required

RoHS and Reach compliant material used

- Maximum device size: 15.1" W x 11.0" D x 1.69" H (38,4 x 28 x 4,3 cm)
- Maximum device weight: ≤ 6.5 lbs (2,9 kg)

PowerShuttle Technology

- Efficient charging system uses Ergotron's innovative patent-pending PowerShuttle Technology to automatically optimize total charge time for up to 20 laptops or mobile devices
- Cart is powered using one country-specific power cord (12.5', 3,8 m) plugged into a wall outlet. Cord wrap is recessed into side of cart
- Never waste time charging an empty set of slots
- Safely prevents overloading electrical circuits by efficiently grouping the number of devices that are charged at one time
- LED status indicators provide users with zone charging status
- How it works: When the cart is plugged in, the system automatically measures and stores the current draw of the external outlet and the power strips inside the cart (5 devices per power strip). Max wall current is 12A for 100-120V countries and 8A for 220-240V countries. The PowerShuttle subtracts the current for the always-on devices (auxiliary outlets) from the max wall current. This leaves the amount of current available for the power strips. PowerShuttle then groups the power strips in the minimum number of groups for charging without exceeding the max wall current
- LED status indicators provide users with power distribution status
- Power (North America/Japan): 100-120V ~ 50/60Hz, 12A
- Power (UK, Europe, Australia, and China): 220-240V ~ 50/60Hz, 8A

Compact Size

- Lightweight; up to 49% smaller than competitive product, this compact cart design makes it easy to safely move from room to room

Durable, Secure Storage

- Robust two-point key and lock assembly keeps devices secure. Double-hinged, locking steel front doors open 180° to reveal storage shelves
- Rugged steel frame construction, steel front and rear doors, and molded fire-rated ABS exterior withstands heavy use of classroom settings
- Separate top and back storage compartments provide IT access to power brick storage
- Four 4" (10 cm) locking medical grade, dual wheel casters

Additional Features PS Laptop Cart Only

- Twenty (20) pre-installed CAT 6 RJ4S Ethernet cables enable remote management of laptops for software updates via Wake On LAN (with customer supplied Ethernet switch)
- Mounting brackets and country-specific internal auxiliary outlet for switch and WAP power

- Laptop Management Cart includes external auxiliary outlet (2 receptacles for North America/ Japan, 1 for all other countries). Power is continuous to these outlets when in use
- Five (5) 12V DC continuous operating fans are included to keep equipment cool during the management process. Not needed for charge-only
- Built-in temperature sensor protects your equipment by shutting down charging activity if the maximum internal cart temperature is exceeded. Charging activity will resume automatically once temperature returns to safe levels

Product Name (color)	PS Laptop Management Cart (black)	PS Laptop Charging Cart (black)
	24-246-085 US/CA/MX	24-291-085 US/CA/MX
Part number	24-247-085 China	24-292-085 China
	24-248-085 Japan	24-293-085 Japan
	24-249-085 UK/SNG/HK	24-294-085 UK/SNG/HK
	24-250-085 EU	24-295-085 EU
	24-251-085 AU/NZ	24-296-085 AU/NZ
Product Includes	20 device slots, 12.5' (3,8 m) power cable, country-specific power strip, cable management tray, four 4" medical-grade locking casters, integrated handle	
Additional Features	20 CAT 6 Ethernet cables, standard 1U Ethernet switch mounting brackets, auxiliary outlet (external), auxiliary outlet (internal for switch and WAP)	One (1) 12V DC continuous operating fan in top compartment
	Five (5) 12V DC continuous operating fans Built-in temperature sensor	
Product Dimensions	28.0" W x 24.4" D x 40.0" H (71,1 x 62.0 x 101,6 cm)	
Shipping Dimensions	32.7" W x 27.6" D x 46.4" H (83 x 70,2 x 117,9 cm)	
Product Weight	157 lbs (71 kg)	146 lbs (66,2 kg)
Shipping Weight	214 lbs (97,1 kg)	203 lbs (92,1 kg)
Warranty	Five (5) years; two (2) years for power module; one (1) year for other electrical components	

© 2015 Ergotron, Inc. rev. 01/20/2015/EA Literature made in US
Content is subject to change without notification

Americas Sales and Corporate Headquarters

St. Paul, MN USA
(800) 888-8458
+1-651-681-7600
www.ergotron.com
sales@ergotron.com

EMEA Sales

Amersfoort, The Netherlands
+31 33 45 45 600
www.ergotron.com
info.eu@ergotron.com

APAC Sales

Tokyo, Japan
www.ergotron.com
apaccustomerservice@ergotron.com

Worldwide OEM Sales

www.ergotron.com
info.oem@ergotron.com





COAST Wholesale
APPLIANCES

BOSCH

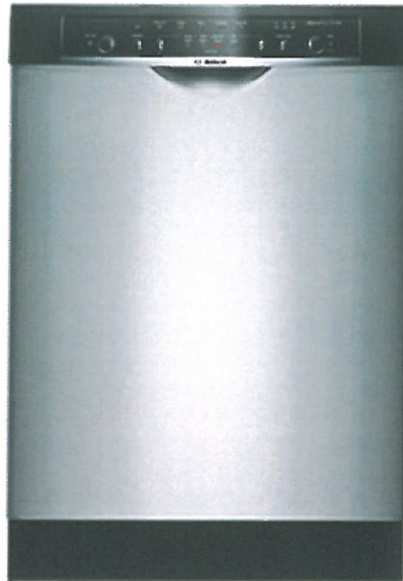

Bosch Full Console Dishwasher
Model# SHE3AR55UC

Feature:

14-Place Settings
4 Wash Cycles
2 Options
Sanitize Option
Delay Start
Standard Racks
50 dBA
Stainless Steel

Dimensions

Width : 23 9/16"
Depth : 22 9/16"
Height : 33 7/8"

Dimensions to be used for preliminary planning only not for construction purposes. Please visit our website for detailed and up to date features and dimensions at www.coastappliances.com





COAST Wholesale
APPLIANCES

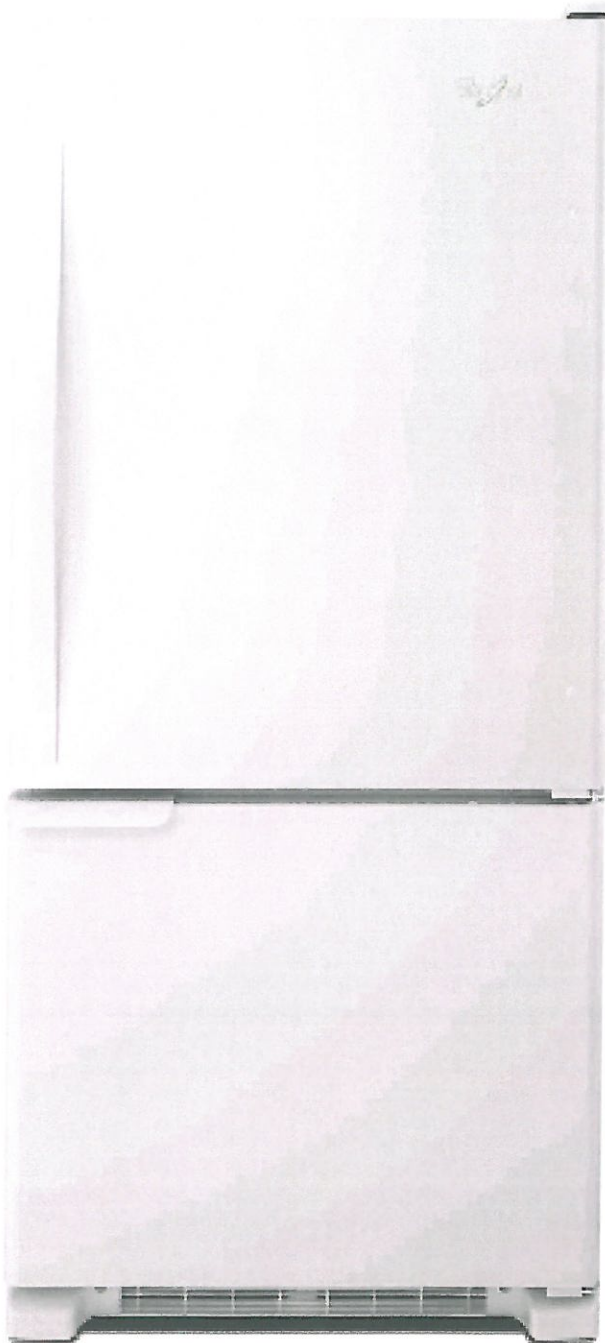

Features:

Accu-Chill™ Temperature Management System
SpillGuard™ Glass Shelves
Adaptive Defrost
LED Interior Lighting
FreshFlow™ Produce Preserver
18.7 Cu Ft Capacity

Dimensions:

Height: 67"
Width: 29 3/4"
Depth: 33 3/8"

Whirlpool Bottom-Mount Refrigerator

Model# WRB119WFBW

Dimensions to be used for preliminary planning only not for construction purposes. Please visit our website for detailed and up to date features and dimensions at www.coastappliances.com





COAST Wholesales
APPLIANCES

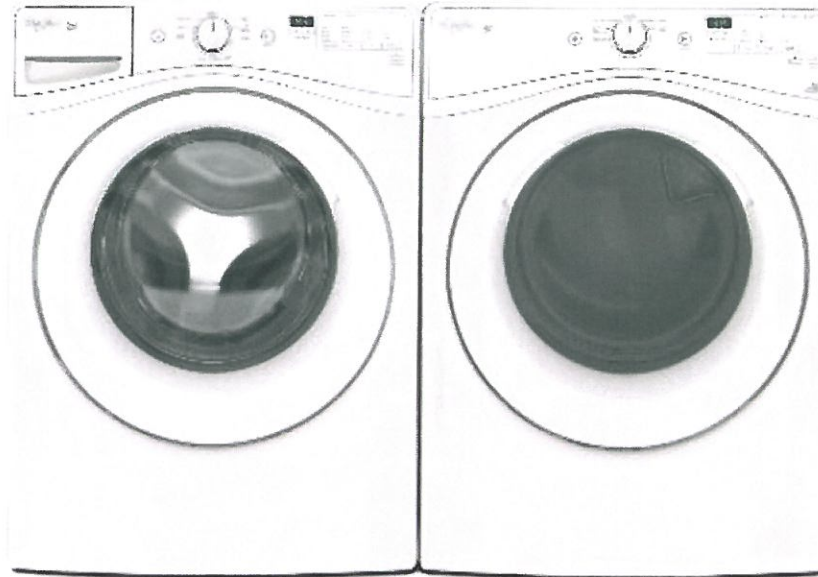

Whirlpool 27" Front-Load Washer

Model# WFW72HEDW

Features:

- 4.2 Cu Ft Capacity
- 4 Temperature Selections
- 8 Cycle Settings
- Smooth Stainless Steel Wash Basket

Dimensions:

- Width: 27"
- Depth: 33 1/8"
- Height: 39 3/4 "
- Depth With Door Open 90°: 52 3/4"
- Minimum Height 38 3/4"
- Maximum Height 39 3/4"

Whirlpool 27" Front-Load Dryer

Model# YWED72HEDW

Features:

- 7.4 Cu Ft Capacity
- 4 Temperature Selections
- 6 Cycle Settings
- Moisture Sensor

Dimensions:

- Width: 27"
- Depth: 31"
- Height: 38 3/4"
- Depth With Door Open 90°: 51"
- Minimum Height: 38 3/4"
- Maximum Height: 39"

Dimensions to be used for preliminary planning only not for construction purposes. Please visit our website for detailed and up to date features and dimensions at www.coastappliances.com





**COAST Wholesale
APPLIANCES**

"Innovative Products for Builders, Designers & Home Owners"

Panasonic®

**Microwave
NNST681S**



DIMENSIONS:

310 x 525 x 401 mm / 12.20" x 20.67" x 15.79"

Dimensions to be used for preliminary planning only not for construction purposes. Please visit our website for detailed and up to date features and dimensions at www.coastappliances.com

Convenient 5 Button Control Panel
1.2 cu ft.

1200 W output power

Sensor reheat

Sensor cook with instant access buttons
(5 categories)

Inverter® Turbo Defrost

Popcorn key

Keep Warm

Quick Minute

Child Safety Lock

Optional trim kit available

Exterior dimensions

Color: Stainless Steel with Black Accents



VACUUM.

**SUGGESTIONS FOR WRITING BID SPECIFICATIONS ON THE
ADVANCE VL500™ 55 or 75**

GENERAL	Machine shall be the type described as a commercial duty, tank style vacuum for use in both wet and dry applications. The tank capacity shall be 14 gallons (55 L) or 19 gallons (75 L).												
MOTOR	The motor shall have a maximum power of 1,100 W and operate at 120 V / 60 Hz. The motor head shall be hinged for easy, no-tools, removal.												
MAIN HANDLE AND TROLLEY	Shall be a fixed stainless steel push handle or an adjustable, folding, push handle with an integrated hanger for power cable storage. Machine tank and motor shall be easily lifted off the trolley with no tools for simple machine maintenance.												
AIRFLOW + VACUUM	Shall be 101 CFM (48 L/sec) and 72 inches of H ₂ O (18 kPa).												
SUCTION POWER	The machine shall have a suction power of 185 W or more at the end of the vacuum tube.												
FILTRATION	The filtration system shall include a single filter set used in both wet and dry applications. The filter set shall include a high capacity cartridge filter that is waterproof, washable, and seals the motor head to ensure full motor protection from debris and liquids. The cartridge filter shall have a minimum filtration area of 683 in ² (4,410 cm ²). The wet filter shall be designed to dissipate foam and have a minimum filtration area of 285 in ² (1,840 cm ²). The filter system shall be a locking stack system to ensure proper alignment and optimum airflow through the vacuum system.												
TANK EMPTY AND CAPACITY	The tank and frame shall include a weight distribution mechanism that allows users to easily dump a full tank without user strain. The machine shall include a drain hose and spout for simple tip-and-pour options to empty the tank. The tank capacity shall be 14 gallons (VL500-55) or 19 gallons (VL500-75).												
SQUEEGEE	Shall include a break-away squeegee system with a simple foot-pedal engagement mechanism.												
BASE	Shall be designed with a wide stance to ensure maneuverability even when the tank is full.												
TOOLS/ ACCESSORIES	Shall have as standard onboard a hose, extension tube, crevice tool, floor nozzle with rubber strip, brush tool, and an optional squeegee kit. The machine shall have integrated tools storage for ease of use and simplified transportation.												
POWER CABLE	Shall be 50 feet (15 m) in length.												
WEIGHT	Shall be 52 pounds (23.5 kg) for the VL500-55 and 61 pounds (27.5 kg) for the VL500-75.												
DIMENSIONS	Shall not exceed: <table><thead><tr><th></th><th><u>VL500-55</u></th><th><u>VL500-75</u></th></tr></thead><tbody><tr><td>Width:</td><td>24 inches (62 cm)</td><td>24 inches (62 cm)</td></tr><tr><td>Length:</td><td>34 inches (84 cm)</td><td>26 inches (66 cm)</td></tr><tr><td>Height:</td><td>40 inches (100 cm)</td><td>41 inches (103 cm)</td></tr></tbody></table>		<u>VL500-55</u>	<u>VL500-75</u>	Width:	24 inches (62 cm)	24 inches (62 cm)	Length:	34 inches (84 cm)	26 inches (66 cm)	Height:	40 inches (100 cm)	41 inches (103 cm)
	<u>VL500-55</u>	<u>VL500-75</u>											
Width:	24 inches (62 cm)	24 inches (62 cm)											
Length:	34 inches (84 cm)	26 inches (66 cm)											
Height:	40 inches (100 cm)	41 inches (103 cm)											

THE MACHINE SHALL BE AN ADVANCE VL500™ 55 or VL500™ 75.

Advance AquaClean® 16ST/16XP/18FLX

Carpet Extractors

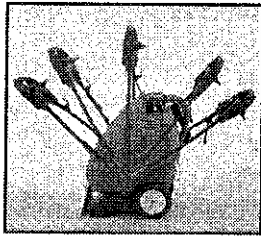

The AquaClean® 18FLX has dual operating modes for traditional pull back or high productivity walk-behind extraction.

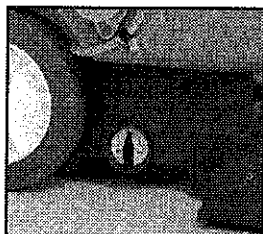

16XP and 18FLX have dual moisture modes for low moisture/ high productivity cleaning or deep restorative cleaning.



Carpet extraction and spotting/upholstery machine in one with integrated hand tool on the 16XP and 18FLX.

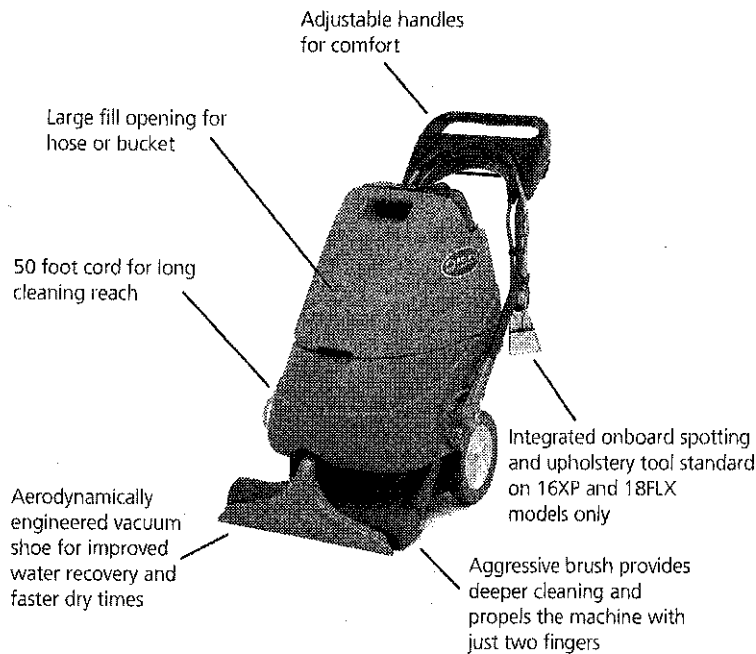

Defining Cleaning Innovation...

- Our products are designed using innovative technology that increases productivity and drives down the cost to clean.
- You can get expert service and maintenance for your Advance machines from factory-trained personnel around the world. Fast parts delivery, too.
- Maintain peak performance with Nilfisk-Advance Parts.

Technical Specifications

Models	16ST	16XP	18FLX
Solution Tank	8 gal (30.3 L)	8 gal (30.3 L)	11 gal (41.6 L)
Recovery Tank	6 gal (22.7 L)	6 gal (22.7 L)	9 gal (34.1 L)
Flow Rate DCM Mode	N/A	0.33 gpm @ 60 psi	0.33 gpm @ 60 psi
Flow Rate Rest. Mode	0.7 gpm @ 60 psi	0.7 gpm @ 60 psi	0.7 gpm @ 60 psi
Vacuum Motor	1.5 hp, 3 stage	1.5 hp, 3 stage	1.5 hp, 3 stage
Brush Motor	1/3 hp	1/3 hp	1/3 hp
Brush Size / Cleaning Path	16 in (40.6 cm)	16 in (40.6 cm)	18 in (45.7 cm)
Vacuum Shoe	18 in (45.7 cm)	18 in (45.7 cm)	20 in (45.7 cm)
Power Cable	50 ft (15 m) Fixed	50 ft (15 m) Detachable	50 ft (15 m) Detachable
Waterlift	117 in (297 cm)	117 in (297 cm)	117 in (297 cm)
Weight			
Net	94 lb (42.64 kg)	100 lb (45.36 kg)	110 lb (49.90 kg)
Shipping	120 lb (54.43 kg)	126 lb (57.13 kg)	180 lb (81.65 kg)
Part Numbers	56265003	56265000	56265001

Specifications are subject to change without notice.



14600 21st Avenue North
Plymouth, MN 55447-3408
www.advance-us.com
Phone: 800-850-6559
Fax: 800-989-6566

240 Superior Boulevard
Mississauga, Ontario, Canada L5T 2L2
www.nilfisk-advance.ca
Phone: 905-564-1149 or 800-668-8400
Fax: 905-564-1030 or 800-263-5111

©2012, Nilfisk-Advance, Inc.,
Printed in U.S.A., Form L1677A, 10-12



Search by keyword, product code...



CALL 1-800-723-4000

View cart
(0 items): **Sub-total: \$0.00**



- [Binding](#)
- [Laminating](#)
- [Shredding](#)
- [Cutting](#)
- [Paper Handling](#)
- [Service](#)
- [Customize](#)
- [Reconditioned Equipment](#)

Home / Laminating / Equipment / Roll Laminators / Desktop / GBC® HeatSeal® Pinnacle 27 EZload® Thermal Roll Laminator, NAP I/II, 27" Max. Width, 6 Min Warm-Up [Sign In](#) [Product Registration](#)

GBC® HeatSeal® Pinnacle 27 EZload® Thermal Roll Laminator, NAP I/II, 27" Max. Width, 6 Min Warm-Up

Thermal roll laminator with EZload simplifies film loading and provides quick and easy laminating. Warms up in just 6-9 minutes to laminate items up to 27" wide with NAP I or II film up to 3 mil thick. Built-in horizontal trimmer helps you turn out clean and polished lamination every time and the control panel includes a handy footage counter.

1701720EZ

Call for a quote 1-800-723-4000

[Compare \(up to 4\)](#)

- [Features](#)
- [Specifications](#)
- [Resources](#)

- Thermal roll laminator with EZload technology eliminates film loading mistakes
- Use with Pinnacle 27 EZload Roll Film up to 3 mil thick
- 6 to 9 minute warm-up time
- Variable speed, laminates up to 12' per minute
- 27" maximum document width
- Additional features include audible alerts, footage counter, temperature readout, auto shutoff and motorized reverse
- Limited 1-year warranty
- 21" x 35.75" x 13.5"



Share this page 8+



GBC® Pinnacle 27 EZload® Roll Laminator
[Watch video](#)



GBC® Pinnacle 27 EZload™ How to Load Video
[Watch video](#)



GBC® Pinnacle 27 Roll EZload™ Laminator
[Watch video](#)

Related Products

Accessories & Supplies



GBC® HeatSeal® Pinnacle 27 Thermal Roll Laminator, NAP I/II, 27" Max. Width, 6 Min Warm-Up



GBC® Ultima® 35 EZload® Thermal Roll Laminator, 12" Max. Width, 1 Min Warm-Up

Trade West Equipment Ltd

Bulman R999 Eight Roll Vertical Paper Rack



Eight Roll Vertical Paper Racks. Designed for use wherever larger quantities of paper are required. The R999 holds eight 9" diameter rolls 36" in width and occupies only 25" x 48½" of floor space and stands 47 1/2" high. Mounted on four strong, smoothly rolling casters, the unit can be positioned and locked in place with integral caster wheel locks for safety and stability. Bulman Vertical Racks incorporate an automatic blade locking device for easy roll changing and spring-loaded blades for sure cutting. Welded steel construction and strong functional design assure durable, long wear life. Finished in attractive gray baked powder coat.

Features

- **Warranty: 1 Year**
- **Weight: 67 pounds**
- **Number of Rolls: 8**
- **Paper Roll Max.: 36"L**



Business Solutions

English

G

[Home](#) [Products & Services](#) [Support](#) [Sales/Service Locator](#) [About](#) [News](#) [Environment](#) [Careers](#)

You are here: [Canada](#) [Business Solutions](#) [Products](#) [Office Systems](#) [Monochrome MFP](#) [bizhub 364e](#)

Monochrome Multifunction Printer/Copiers

[Business Solutions](#)

[Products](#)

[Office Systems](#)

[Colour MFP](#)

[Monochrome MFP](#)

[bizhub 215](#)

[bizhub 224e](#)

[bizhub 25e](#)

[bizhub 284e](#)

[bizhub 364e](#)

[bizhub 4050](#)

[bizhub 454e](#)

[bizhub 4750](#)

[bizhub 554e](#)

[bizhub 654e](#)

[bizhub 754e](#)

[Printers](#)



bizhub 364e

The bizhub 364e puts you in total control, with a colour display as simple to operate as a tablet -- to print and copy both colour and B&W documents at up to 160 original copies. You control the solutions your business depends on. You have security options, auto finishing and more -- everything to increase productivity.

[Request a call](#)

[Overview](#)

[Accessories](#)

[Applications](#)

Overview

bizhub 364e

Key Features:

B&W: 36 ppm

Max Paper Capacity: 3,650 sheets

Optional Dual Scanning: 160 opm

Enhanced multi-touch interface

Other Features:

High-speed 36 ppm B&W print/copy output to keep ahead of rising demands

Optional dual scanning at up to 160 opm to capture originals in both colour and B&W

Built-in Emperon print system with PCL6/PS3 emulation, native XPS

Large 9" colour display -- as simple to operate as a familiar tablet

Multi-touch functions: swipe, drag, double-tap, toggle, pinch

Transparent menus, customizable icons, improved soft keyboards

Downloadable apps to make you more productive

Complies with IEEE 2600.1 international security standard

[Terms of Use](#) [Privacy Policy](#) [Sitemap](#)

[Global Site](#)

©2014 Konica Minolta Business Solutions (Canada) Ltd.



MFP

bizhub C364e
COLOUR MID-VOLUME MULTIFUNCTION PRINTER

bizhub C364e

Ideal for growing businesses, the bizhub C364e is a powerful, affordable colour MFP with superior Simitri HD image quality and fast 36 ppm print/copy output. Optional dual scanning at up to 160 opm brings information into your workflow faster – and enhanced touchscreen simplicity never slows you down.

System Overview

System memory	2,048 MB
System hard disk	250 GB
Interface	10BASE-T/100BASE-TX/1000BASE-T Ethernet, USB 2.0
Network protocols	TCP/IP (IPv4/IPv6), SMB, LPD, IPP, SNMP, HTTP, HTTPS
Frame types	Ethernet 802.2, Ethernet 802.3, Ethernet II, Ethernet SNAP
Dual scan document feeder (optional)	Up to 100 originals / 5.5" x 8.5" to 11" x 17" / 35-163 gsm Reversing automatic document feeder or dual scan document feeder available
Printable paper size	Scanning/Copying: up to 11" x 17" Printing: up to 11" x 17" full bleed on 12" x 18" paper Custom paper sizes Banner paper 11.75" x 47.25" max
Printable paper weight	52-300 gsm
Paper input capacity	Standard: 1,150 sheets / Max.: 3,650 sheets
Tray 1	500 sheets / 5.5" x 8.5" to 11" x 17" / 52-256 gsm
Tray 2	500 sheets / 5.5" x 8.5" to 12" x 18" / 52-256 gsm
Tray 3 (optional)	500 sheets / 5.5" x 8.5" to 11" x 17" / 52-256 gsm
Tray 4 (optional)	2 x 500 sheets / 5.5" x 8.5" to 8.5" x 11" / 52-256 gsm
Large capacity tray PC-410 (optional)	2,500 sheets / 8.5" x 11" / 52-256 gsm
Manual bypass	150 sheets / 4" x 6" to 12" x 18" / custom paper sizes / 50-300 gsm
Automatic duplexing	5.5" x 8.5" to 12" x 18" / 52-256 gsm
Finishing modes	Offset, group, sort, punch, half-fold, tri-fold, booklet
Output capacity	Max. with finisher: 3,300 sheets Max. without finisher: 250 sheets
Stapling (optional)	Max.: 50 sheets or 48 sheets + 1 cover sheet (up to 209 gsm)
Stapling output capacity	Max.: 1,000 sheets
Tri-fold	Up to 3 sheets
Tri-fold capacity	Max.: 30 sheets (tray)
Booklet	Max.: 20 sheets or 19 sheets + 1 cover sheet (up to 209 gsm)
Booklet output capacity	Max.: 100 sheets (tray)
Copy/print volume	Max.: 125,000 pages/month ¹
Toner lifetime	Black: 27,000 pages / CMY: 25,000 pages
Imaging unit lifetime	Black: 120,000 pages / 590,000 pages (Drum / Developer) CMY: 90,000 pages
Power consumption	120 V / 50/60 Hz, less than 1.5 kW (system)
System dimensions	24.2" x 27" x 31" (W x D x H)
System weight	Approx. 185.18 lb

Copier Specifications

Copying process	Electrostatic laser copy, tandem, indirect
Toner system	Simitri™ HD Polymerized Toner
Print speed (8.5" x 11")	B&W / Colour: up to 36 ppm (Portrait)
Print speed (11" x 17")	B&W / Colour: up to 18 ppm (Portrait)
Autoduplex speed (8.5" x 11")	B&W / Colour: up to 36 ppm (Portrait)
1st copy out time	B&W: 5.3 sec / Colour: 6.9 sec
Warm-up time	Approx. 20 sec ²
Copy resolution	600 x 600 dpi
Gradations	256 gradations
Multi-copy	1-9,999
Original format	Up to 11" x 17"
Magnification	25-400% in 0.1% steps, auto zooming
Copy functions	Electronic sorting, multi-job adjustments (contrast, sharpness, image density), proof copy, interrupt mode, colour mode, separate scan, sort/group, combination, original selection, ID card copy 2-in-1, 4-in-1

Printer Specifications

Print resolution	1800 x 600 dpi, 1200 x 1200 dpi
PDL	PCL 6 (xL 3.0), PCL 5c, PostScript 3 (ver. 3016), XPS
Operating systems	Windows (x32/x64) XP / Vista / 7 / 8 Windows Server (x32/x64) 2003 / 2008 / 2008 R2 ¹ / 2012 ² Macintosh OS X 10.2.8 or later UNIX / Linux / Citrix
Printer fonts	80 PCL Latin, 137 PostScript 3
Print functions	Direct Print of PCL, PS, TIFF, XPS, PDF, encrypted PDF files and OOXML (DOCX, XLSX, PPTX), multimedia and mixplex, "Easy Set" job programming, overlay, watermark, copy protection, carbon copy print

Printer Specifications (optional)

Print controller	Embedded Fiery IC-414
Memory / HDD	2 GB / 160 GB
PDL	PostScript 3 (ver. 3019) PCL 6/5c
Operating systems	Windows (x32/x64) XP / Vista / 7 / 8 Windows Server (x32/x64) 2003 / 2008 / 2008 R2 ¹ / 2012 ² Macintosh OS X 10.2.8 or later

Scanner Specifications

Scan speed	B&W / Colour: up to 160 opm with optional DF-701
Scan resolution	Max.: 600 x 600 dpi
Scan modes	Scan-to-Email, Scan-to-SMB, Scan-to-FTP, Scan-to-Box, Scan-to-USB, Scan-to-WebDAV, Scan-to-DRWS, Network TWAIN scan
File formats	JPEG, TIFF, PDF, PDF/A 1a and 1b (optional), compact PDF, encrypted PDF and searchable PDF (optional), XPS, compact XPS, PPTX and searchable PPTX (optional), searchable DOCX/XLSX (optional)
Scan destinations	2,100 (shared with fax), LDAP support
Scan functions	Annotation (text/time/date) for PDF, up to 400 job programs, realtime scan preview

Fax Specifications

Fax	Super G3 (optional)
Transmission	Analog, i-Fax, Colour i-Fax, IP-fax
Resolution	Max.: 600 x 600 dpi (ultra-fine)
Compression	MH, MR, MMR, JBIG
Modem	Up to 33.6 Kbps
Destinations	2,100 (single + group)
Functions	Polling, time shift, PC fax, receipt to confidential box, receipt to email/FTP/SMB, up to 400 job programs

User Box Specifications

Storable documents	Max.: 3,000 documents or 10,000 pages
Type of user boxes	Public Personal (with password or authentication) Group (with authentication)
Type of system boxes	Secure Print, Encrypted PDF, Fax receipt, Fax polling, Annotation
User box functionality	Reprint, combination download, sending (email/FTP/SMB and fax), copy box to box

Minuteman[®]
Excellence Meets Clean



Front Runner Floor Machines

13", 17" & 20" floor machines

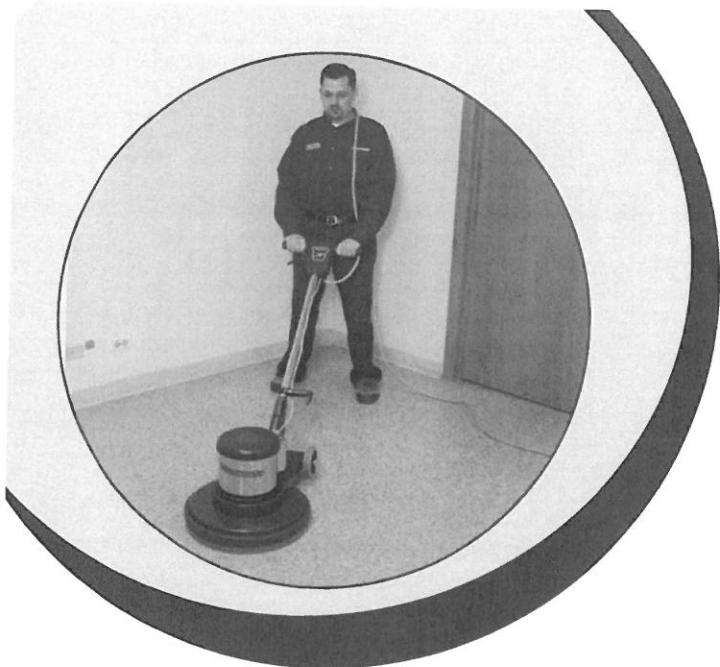

Key Features

- Infinitely adjustable ergonomic handle
- Heavy duty frame construction
- Multiple sizes and speeds to fit all cleaning applications
- Heavy duty planetary gears for smooth operation
- Built to operate in commercial and industrial applications
- 17" and 20" machines come with pad driver at no additional cost, 13" does not come with the pad driver

Safety

- Heavy duty 14-3 jacketed power cable designed for long wear
- Hospital grade plugs that meet all health care compliance regulations
- Safety interlock switches prevents accidental machine operation
- Heavy duty non-conductive strain relief protects operator and power cable
- Wrap-around bumper protects all environmental surroundings
- Carbon brush indicator light on two speed machines
- Power indicator light lets the operator know when the machine has power
- All operator control handles are non-conductive to protect the operator

Markets

- Hospitality
- Institutional
- Industrial
- Health Care

Accessories/Options

- Multiple brush grits to meet all cleaning needs
- Pad drivers
- Solution tanks

General Overview

- Powder coated epoxy paint helps eliminate scratching and corrosion
- Large 4.5" non-marking transport wheels
- All 17" and 20" floor machines come standard with 1.5 hp, triple planetary gears
- 20" machines are available in dual speed
- 13" ¾ hp machines are available for "tight" cleaning situations
- All handles are made of tubular coated steel to resist rust and corrosion
- All machines are equipped with a 50' 14-3 wire heavy duty water resistant power cord

Productivity

- Many types of brushes, pads and scrubbing heads are available to use on the Front Runner Floor Machines
- Heavy duty capacitor start provides the needed power even in the toughest cleaning situations
- Available in three sizes to meet all your cleaning needs
- Whether its carpets, wood floors, concrete or stone, the Front Runner series machine will help get the job done

Ease of Use

- Infinitely adjustable handle from operator position
- Quick release cord latch
- Large non-marking 4.5" rear wheels for easy transport
- Simple safety release power switch
- Pad holder with center cup keeps pad evenly mounted

Specifications				
Model Number	M13075-00	FR17115	FR20115-2S	FR20115
Model Numb. -240V	N/A	FR17220	FR20220-2S	FR20220
Brush Diameter	13" (43 cm)	17"/43 cm	20"/51 cm	20"/51 cm
Horsepower	3/4 hp	1-1/2 hp	1-1/2 hp	1-1/2 hp
Brush Speed	175 rpm	175 rpm	160-330 rpm	175 rpm
Cable Length	50' (15 m)	50'/15 m	50'/15 m	50'/15 m
Cable Size	14-3	14-3	14-3	14-3
Wheels	3-1/2"/9 cm	4-1/2"/11 cm	4-1/2"/11 cm	4-1/2"/11 cm
Weight (with brush):	60 lbs (27 kg)	100 lbs/45 kg	103 lbs/47 kg	103 lbs/47 kg

Specifications subject to change without notice.

Minuteman International Inc
 14N845 U.S. Route 20
 Pingree Grove, IL 60140
 Phone: (847) 264-5400
 Fax: (847) 683-5207

Minuteman is a full line manufacturer of maintenance products including critical filter vacuums, industrial and commercial vacuums, sweepers, scrubbers, floor and carpet machines, PowerBoss® sweepers and scrubbers, and Parker® Litter Vacs for industrial, commercial, and institutional facilities.

A Member of the Hako Group

Come Visit our Website at
www.minutemanintl.com



20 cu. ft. Upright Freezer with Temperature Alarm



20 cu. ft. Upright Freezer with Temperature Alarm

Put a spotlight on your frozen favorites inside this 20 cu. ft. upright freezer with LED interior lighting. Activating Fast Freeze quickly drops the temperature to help lock in freshness and flavor, and the temperature alarm will notify you if the freezer gets too warm. The upright freezer prevents frost build-up for a hassle-free defrosting experience, and you can choose the ideal temperature for whatever frozen foods you're storing with electronic temperature controls. Plus, you can be sure there is plenty of ice on hand with the optional icemaker.

Configuration and Overview

- Freezer Type
- Upright
- Energy Star® Qualified
- CEE Tier Rating

Freezer Features

- Door Ajar Alarm
- Fast Freeze Setting
- Power On Indicator Light
- Defrost Drain
- Door Lock
- Defrost Type
- Automatic Defrost
- Temperature Monitor Alarm
- 33 ¼" Wide X 72" High x 27 ½" Depth
- Power: Electric CSA Rating Household

FRIGIDAIRE FEF3048LS ELECTRIC RANGE



Electrical Specifications: 240V / 208V 60Hz

Exterior Dimensions:

Height: 47 – 3/4"

Width: 29 - 7/8"

Depth: 25 – 3/4"

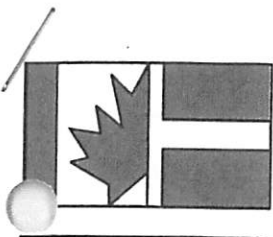

CAN-DAN REHATEC LTD.

3-1378 Sandhill Drive,
Ancaster, Ontario L9G 4V5

Phone: (905) 648-7522

Fax: (905) 648-7799

Mobile Electrically Height Adjustable Change Table.

The Change Table is infinitely variable in height, within a range of approx. 16".

Powered by a 115VAC to 24VDC Actuator.

The top has a removable Grey mattress, with hook'loop fasteners on the bottom, and 2 body safety belts.

Mattress outer covering is 19oz. Qualovin Vinyl, treated for germ resistance and fire-retardant.

The table is adjustable from approx. 20" to 36".

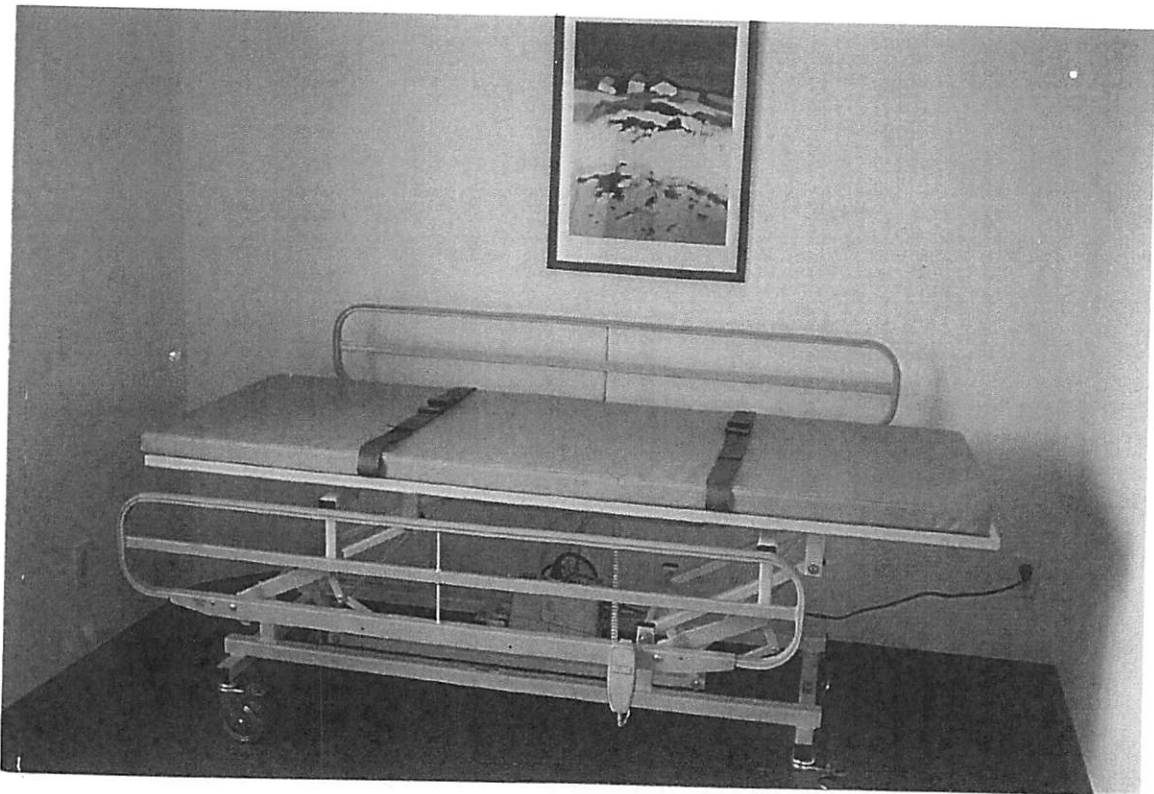

Above picture shows Change Table with optional "Side-Rails"

Model #	Size	Model #	Size	Model #	Size
19-97-62	62" x 28"	20-02-62	62" x 30"	20-03-62	62" x 32"
19-97-72	72" x 28"	20-02-72	72" x 30"	20-03-72	72" x 32"

BE GOOD TO YOUR BACK - WHEN HELPING OTHERS.

Manufactured in Canada by Can-Dan Rehatec Ltd.

Independent Living Inc
3870 Eastgate Drive
Regina, Sk S4Z 1A5
352-2579 1-800-667-6003

Nicros-EasyWall™

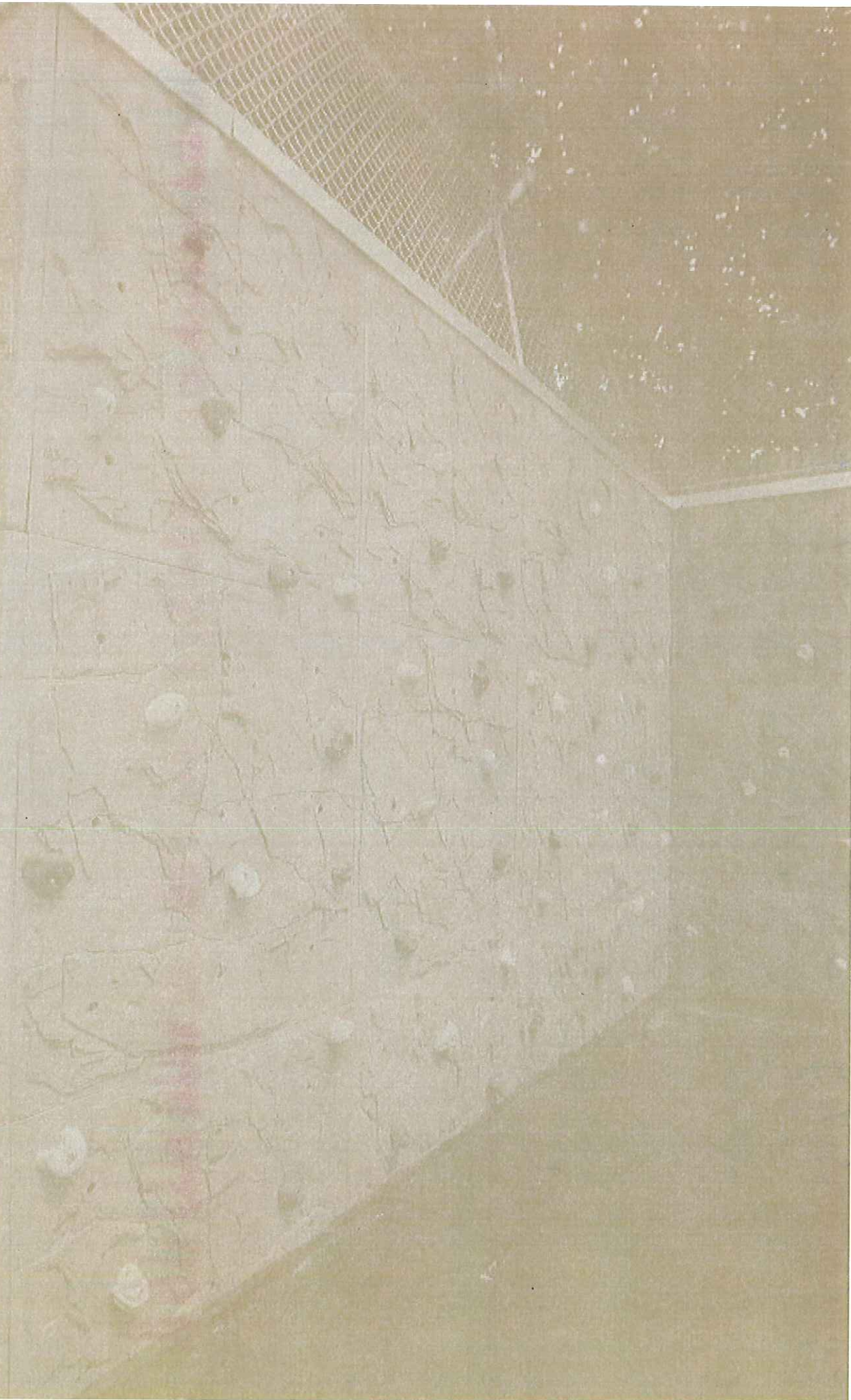

What is Nicros-EasyWall™?

Nicros-EasyWall™ is a uniquely designed lightweight 4'x4' panel system. It is named "easy wall" because installation is as easy as bolting it to an existing wall. Each panel is two to three inches thick and also has natural crack-like features that line up with the adjoining panels, regardless of how they are oriented. This attention to detail yields a realistic and beautiful climbing wall.

The advantage to Nicros-EasyWall™ is that it's a low-cost, easy-to-install system that takes up very little space. Many schools use this product to create a bouldering wall, but it's also used in recreation centers, rehabilitation centers, health clubs, and residential properties for both bouldering walls and full-height climbing walls.

Each panel comes with five handholds to get you started but the number you'll need will depend on the climber's age and ability. The holds come in a combination of "kid-friendly" colors such as red, blue and yellow and "earth tone" colors such as tan, grey, and brown to match your panels.

The surface of Nicros-EasyWall™ panels is grippy enough that a climber can hang onto the micro-features or smear against the panel itself.

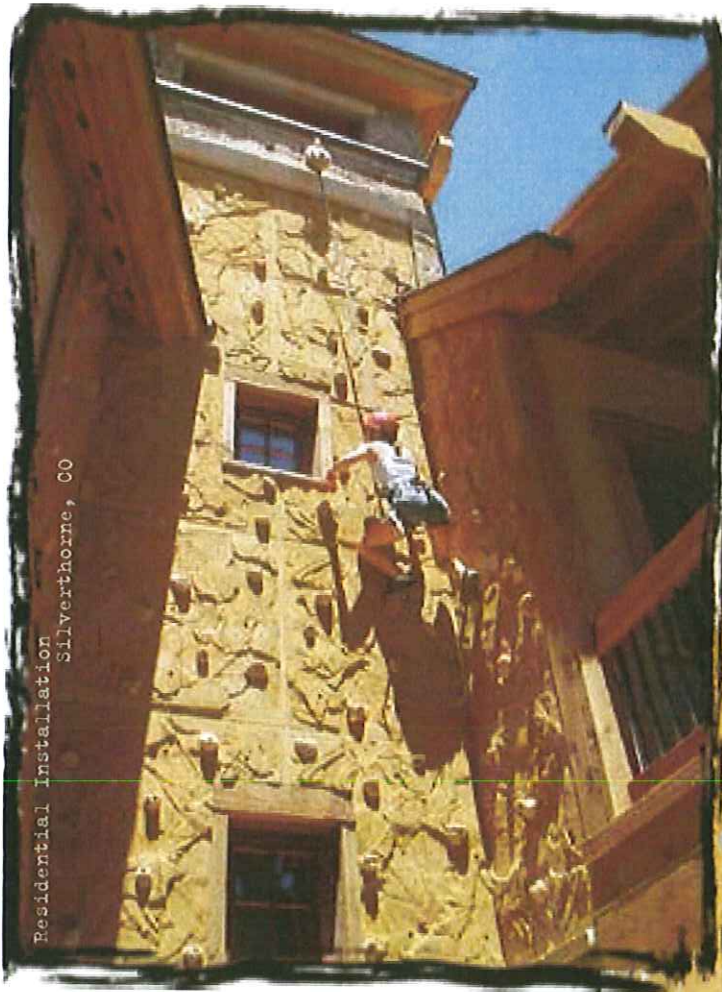

Residential Installation
Silverthorne, CO

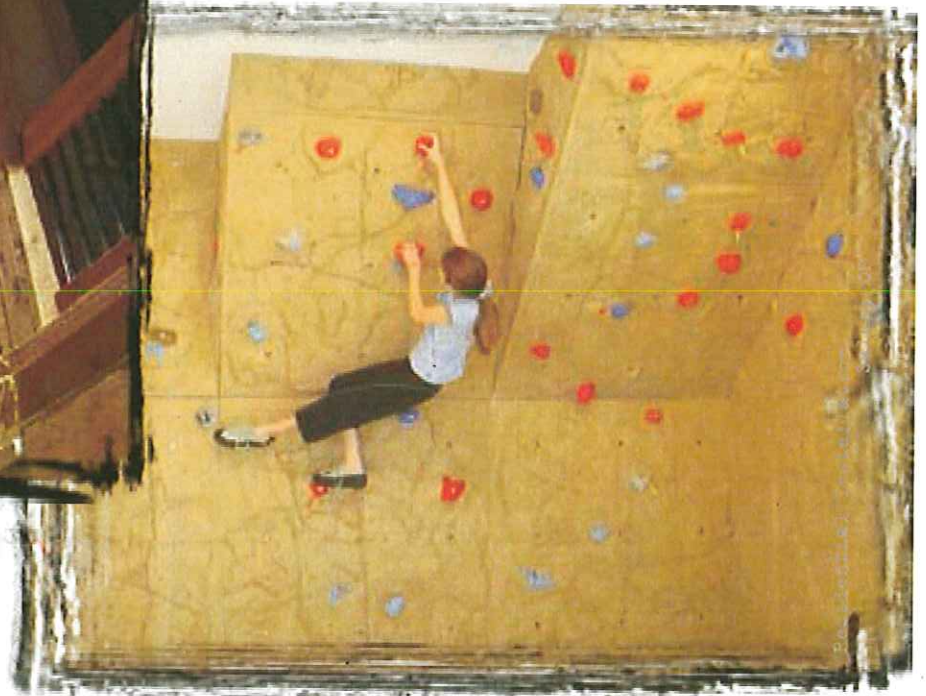

"The perfect place for putting a home training wall turned out to be the room we promised to my 13-year-old daughter. As we planned the remodel of the room, we showed our contractor Climbing Magazine's article on building your own gym. Phone calls and web-surfing quickly led us to Nicros-EasyWall™ as the most affordable and versatile choice. I designed the wall with a 22.5 inch, 45 degree overhang, and we have been having a blast ever since. We're even thinking of extending it to the other walls and ceiling of her bedroom!"

- Jenni Neahring, Residential Installation, Salem, OR

Installation is as easy as 1, 2, 3... Installation involves mounting Nicros-EasyWall™ panels to an existing wall such as a concrete block wall. Installation typically happens at a rate of two panels per person per hour. This means that, in less than five hours, a ten panel bouldering wall could be installed by one person! While installation is easy, it's very important that it be done correctly. We suggest consulting a licensed structural engineer to ensure correct and safe attachment of the panels to your building.

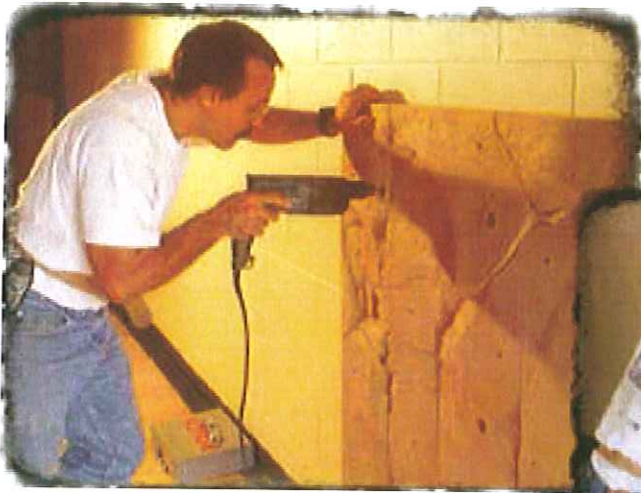

Pilot holes are drilled into the C.M.U. Block or poured concrete wall with a hammer drill.

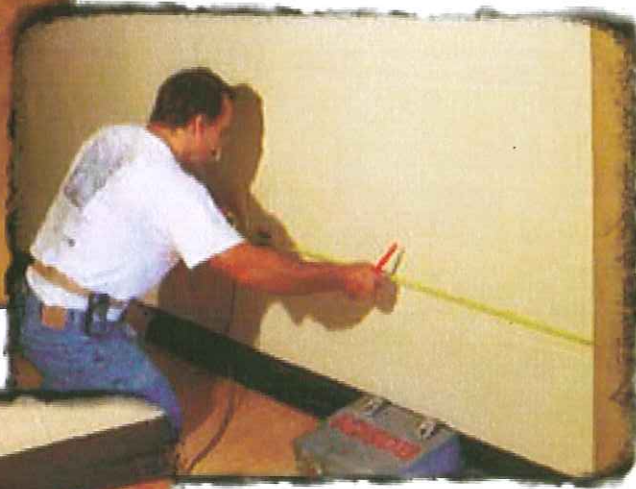

Measuring the location of the obstacle, such as an electrical outlet, allows for a nice, clean finished look.



Standard woodworking tools can be used to trim a panel to fit, or to cut around any existing electrical outlets, switches, etc. to customize installations.



Panels are set in place and the holes are drilled. Final attachment is simple with the use of standard hand tools (e.g. socket wrench).

There are a number of different panel designs and each is usable in four different orientations. The edges, incuts, and micro-terrain of these panels are meant to be used by climbers for hand and footholds and were designed to be of a particular grade in each orientation. If placing a series of panels for use on a full-height climbing wall, "naturals" routes of various difficulties can be created – before handholds are even added to the wall!

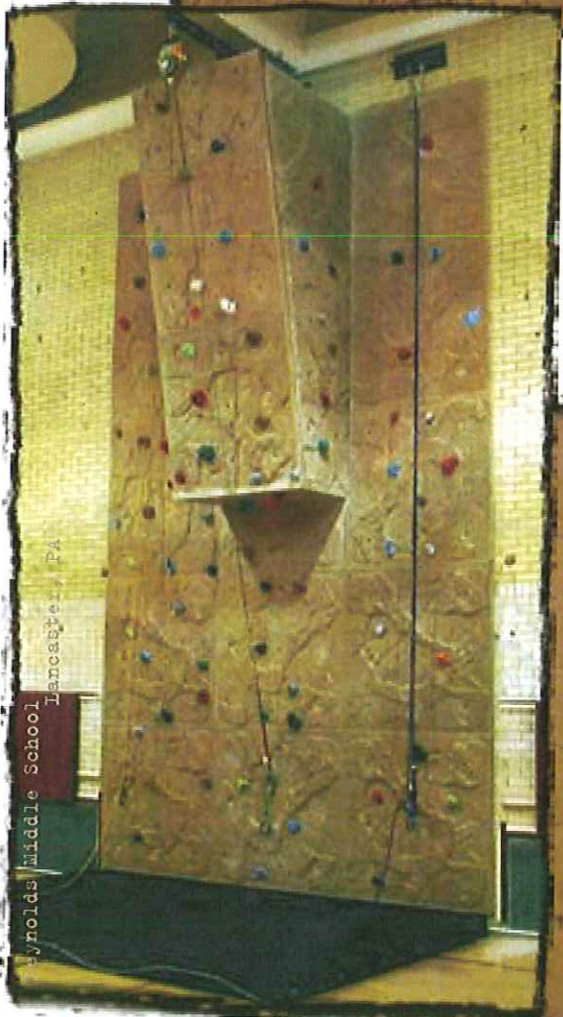

Arnolds Middle School
Lancaster, PA

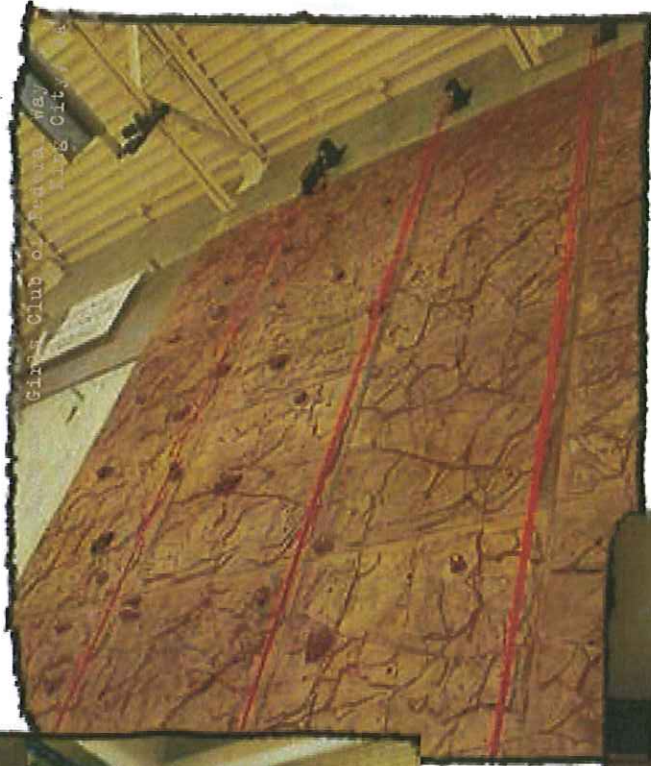

Star Club of the Way
Lodge City

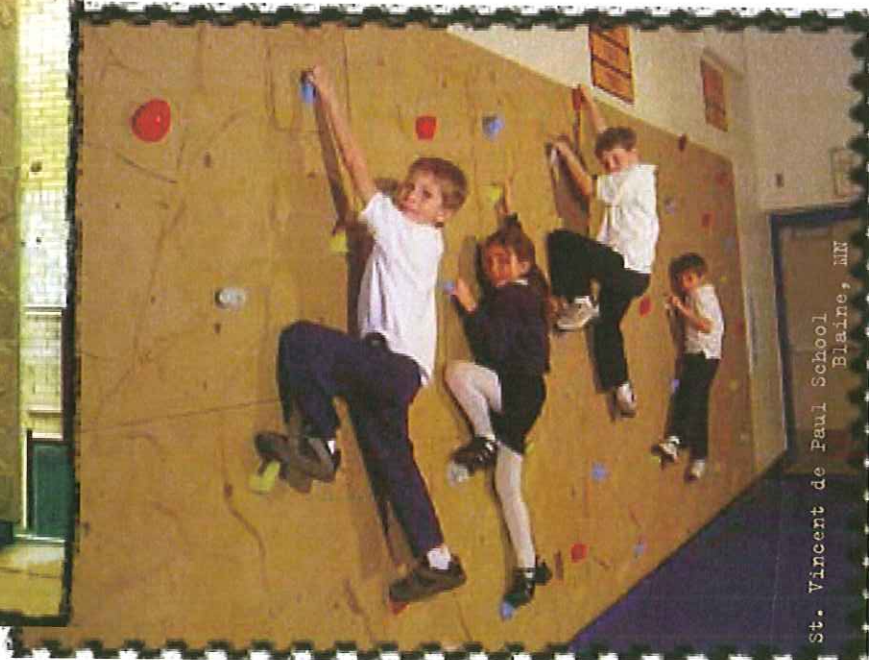
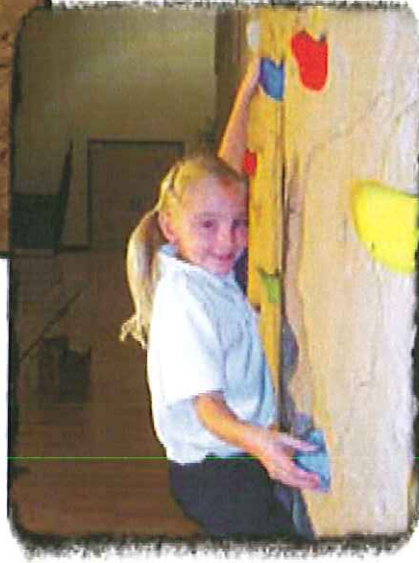

St. Vincent de Paul School
Blaine, MN

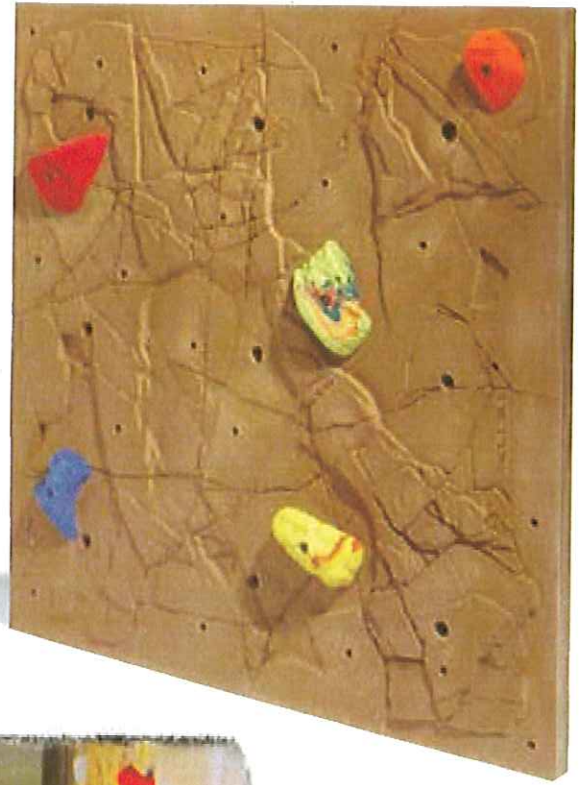

Nicros Climbing Walls
651.778.1975
www.nicros.com
20
(twenty nine)

Nicros-EasyWall™

SYSTEM DESCRIPTION

Nicros-EasyWall™ is a uniquely designed rock climbing wall panel system that is named "EasyWall" because installation is as easy as bolting it to an existing wall. Nicros-EasyWall™ is a light-weight 4'x4' rock climbing panel system that comes with handholds, mounting hardware, installation manual and is paint able.

PRODUCT

Panel:

- 48" x 48" with a +/-1/4" tolerance
- 45-50 lbs.
- Maximum 4" projection from back (zero) plane
- Rock-like look
- Dry "feel"
- Uniform texture
- Non-warping
- Defect free, internally and externally
- Thermal stability to minimum 180°
- UV resistant
- Shore D hardness > 40
- Edge return to the zero plane
- Edges of uniform thickness
- Hand tooling of material (cut to fit)

Handhold Attachment Points (HAP):

- 22-28 HAP per panel
- HAP perpendicular to local orientation plane (2-8" diameter areas)
- HAP orientation planes variable
- HAP pull out load of minimum of 1300 lbf

Anchoring Points:

- Back of anchor points at zero plane
- 16" center for anchor points with a +/-1/4" tolerance
- Anchor point pull-out load minimum of 1300 lbf

FASTENERS

- 9 Hilti 14 X 3.25 Torx IHWH concrete screws with washers attach each panel to CMU walls
- 9 3/8 X 3 zinc plated lag screws with washers attach each panel to wood walls

WARRANTY

A one year warranty is provided to the original purchaser ensuring the product is free from defects in material and workmanship.



BEVERAGE-AIR

3779 Champion Blvd., Winston-Salem, NC 27105
1-888-845-9800 Fax# 1-336-245-6453
<http://www.Beverage-Air.com>

CUSTOMER'S CHOICE FOR A HOT LOCATION
Tested & Certified to Ambient Class of 100°F

3 Year Parts/Labor Warranty
Additional 2 Year Compressor Warranty

MARKETMAX™ MERCHANDISER SERIES—GLASS DOOR MERCHANDISER

Double section glass door merchandiser with lighted sign panel used for merchandising and storage of frozen food, frozen novelty items and cold product.

CABINET CONSTRUCTION

Heavy duty construction includes white coated steel interior walls. Exterior finish is heavy-duty steel with a baked on durable coating. Choose from black or white finish. S/S exterior and black interior options are available.

Foamed-in-place CFC and HCFC-free polyurethane insulation.
Modern, one-piece grille is easily removed for cleaning and servicing.

Refrigerators have double pane, lowE argon filled glass doors. Freezer models have heated triple pane glass. Inside and outside panes are tempered for added safety. Anti-microbial door handles are standard. Doors provide automatic hold-open feature.

Brightly lighted sign panel.

SHELVING

Five (5) heavy duty epoxy coated wire shelves per section standard.
Four (4) shelf clips included per shelf (field installed).
Shelves are adjustable in 1/2" increments.

ELECTRONIC CONTROL

Electronic thermostat with manual defrost button provides a digital display of cabinet temperatures, which includes status indicators and key pad for any necessary temperature adjustments.

REFRIGERATION

Self-contained bottom mount refrigeration system. Expansion valve refrigerant control on freezer provides quick temperature pull down and reduces compressor run time—meaning reduced energy consumption. Includes automatic condensate disposal. Refrigerators utilize ozone friendly R134a refrigerant. Freezers utilize ozone friendly R404A refrigerant and its defrost system is fully automatic, time-initiated and temperature terminated operation.

Freezer product temperatures from -10°F to -15°F.
Refrigerator product temperatures from 36°F to 38°F.

ELECTRICAL

Interior fluorescent lighting enhances product illumination. Optional LED lighting provides hidden light source for increased product visibility. LED bulbs last up to 10 times longer compared to fluorescent bulbs and renders additional energy savings due to reduced wattage load on compressor.

Item No. _____
Quantity _____

**HINGED GLASS DOOR
MARKETMAX™
MERCHANDISER SERIES**
MM44 Refrigerator and Freezers
Double Door

MODELS:
MMR44-1-B
MMR44-1-W
MMR44-1-B-LED
MMR44-1-W-LED
MMF44-1-B
MMF44-1-W
MMF44-1-B-LED
MMF44-1-W-LED



MMR44-1-B
(SHOWN IN BLACK EXTERIOR)
White and S/S Exterior
finishes available



MMF44-1-W
(SHOWN IN WHITE EXTERIOR)
Black and S/S Exterior
finishes available

SPECIAL FEATURES

- MMR44 and MMF44 have earned the ENERGY STAR®
- Anti-microbial door handles
- Electronic control with digital display
- Brightly lighted sign panel
- Optional LED lighting
- **Available options:** S/S Exterior, Black Interior, Wine Racks, Spring Feed Dividers, Casters, Audible Alarm With PM Feature, Smart Defrost

ELECTRICAL CONNECTION

Refrigerator units wired at factory and ready for connection to a 115/60/1 phase, 15 amp dedicated outlet. Freezer units wired at factory and ready for connection to a 115/60/1 phase, 20 amp dedicated outlet. 8' long cord and plug set included.



115/60/1
NEMA-5-15P
Refrigerator



115/60/1
NEMA-5-20P
Freezer

ELECTRICAL CONNECTION

Units pre-wired at factory and include 8' long cord and plug set.

Available From:



*Note: Not all markings may apply to all model variations.

Model Specified _____

Store# _____

Location _____

Quantity _____



BEVERAGE-AIR

MarketMax™ Glass Door Merchandisers

Model: MMR44, MMF44

MODEL	MMR44	MMF44
EXTERNAL DIMENSIONAL DATA		
Length Overall (inches)	47"	47"
Length Overall (mm)	1194	1194
Depth Overall (inches) - includes handle	33 3/4"	33 3/4"
Depth Overall (mm) - includes handle	857	857
Height Overall— (inches)	78"	78"
Height Overall— (mm)	1981	1981
Number of doors	2	2
Depth with Door Open 90 °	60"	60"
INTERNAL DIMENSIONAL DATA		
NET Capacity (cubic ft.)	45	45
NET Capacity (Liters)	1274	1274
Internal Length Overall (inches)	44"	44"
Internal Length Overall (mm)	1118	1118
Internal Depth Overall (inches)	28 1/2"	28 1/2"
Internal Depth Overall (mm)	724	724
Internal Height Overall—(inches)	61 3/4"	61 3/4"
Internal Height Overall—(mm)	1569	1569
Number of shelves	10	10
ELECTRICAL DATA		
Full Load Amperes 115/60/1	8.8 A	13.8 A
REFRIGERATION DATA		
Horsepower	1/3	3/4
WEIGHT DATA		
Gross Weight (Crated lbs)	530	560
Gross Weight (Crated kg)	240	254

PLAN VIEWS

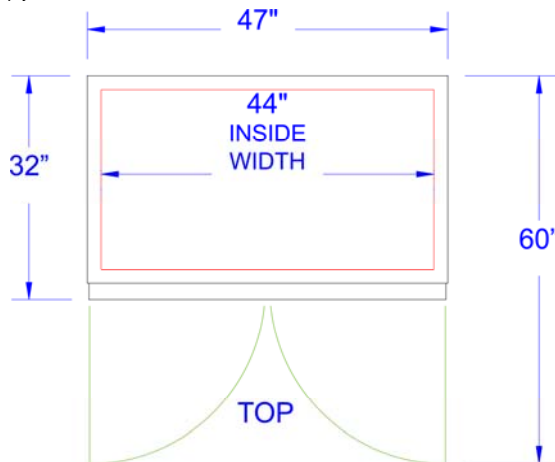
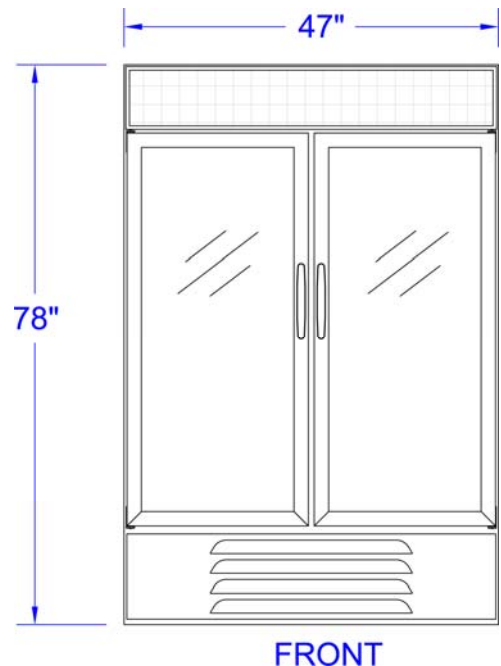
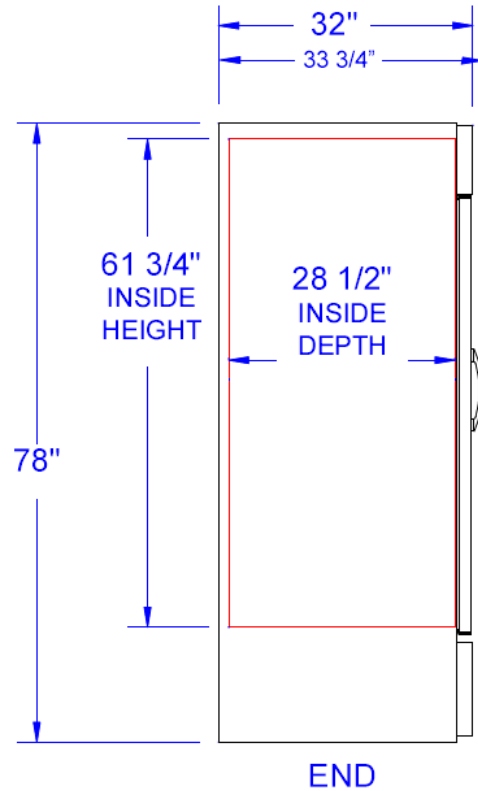

Note: Not all markings may apply to all model variations.

BEVERAGE-AIR® CORPORATION

3779 Champion Blvd. • Winston-Salem, NC 27105 USA • (336) 245-6400 • Fax (336) 245-6453 • (888) 845-9800 • www.beverage-air.com



Specifications are subject to change without prior notice. 06/13



- Financing
- Live Chat or Call
- Available Contracts
- Coupons



Dell Color Printer - C1760nw with 1-Year ProSupport Warranty

Experience excellent print quality and reliable printing with Dell™ C1760nw Color Printer. Get professional business quality prints with crisp text and sharp images, up to 600 x 600 dpi resolution. Performing ... [Full Description](#)

Dell Price..... **\$507.95**

[Add to Cart](#)

Usually Ships: Within 1-2 business days

Manufacturer Part# : 00001 | Dell Part# : DFS1760

- Overview
- Tech Specs

Highlights

- • Offers printing speed of up to 15 ppm mono and up to 12 ppm color
- Equipped with 384 MHz processor speed
- Incorporates 128 MB memory
- Offers high-volume print capacity with a maximum duty cycle of 30,000 pages per month
- Delivers professional business quality prints with up to 600 x 600 dpi resolution
- Contains a high-input 150-sheet paper tray

Overview

Experience excellent print quality and reliable printing with Dell™ C1760nw Color Printer. Get professional business quality prints with crisp text and sharp images, up to 600 x 600 dpi resolution. Performing efficiently at print speeds of up to 15 pages per minute (ppm) mono and 12 pages per minute (ppm) color (Letter Size / A4) the C1760nw can reliably produce high quality printing at a maximum monthly duty cycle of up to 30,000 pages. Also, it features a small intelligent self-scanning print head and enhanced imaging controller, with low maintenance. Additionally, built-in Ethernet and Wi-Fi connectivity enables shared use of this printer among multiple users and extends greater value and savings.

Furthermore, get the excellent print quality and reliable printing using a four-row LCD display with 34 buttons and five LED indicators. It is equipped with LED printing technology which delivers superior print quality, lower energy consumption and maintenance-free performance. Also, this printer is Energy Star® certified, making it more power efficient than conventional models and lets you print vivid, bright and vibrant printouts with ease. This product has been tested and validated on Dell systems. It is supported by Dell Technical Support when used with a Dell system.

Manufacturer Part# : 00001
Dell Part# : DFS1760

© 2015 Dell

[Regulatory Compliance](#)

[Terms of Sale](#)

[Unresolved Issues](#)

[Privacy](#)

[Ads & Emails](#)

[Dell Recycling](#)

[Contact](#)

[Site Map](#)

[Visit ID](#)

[Feedback](#)

[Products](#) ▼

Offers subject to change, not combinable with all other offers. Taxes, shipping, handling and other fees apply. U.S. Dell Small Business new purchases only. LIMIT 5 DISCOUNTED OR PROMOTIONAL ITEMS PER CUSTOMER. Dell reserves right to cancel orders arising from pricing or other errors.